

Lesson 1 Electrolysis

[Click](#) here for a detailed explanation of electrolysis

- It is a non-spontaneous process where energy is supplied by an external source to drive the redox reaction.
- Reduction occurs at the cathode and oxidation occurs at the anode.
- Cathode has a negative polarity while the anode is positive.
- Electrodes can be inert or can take part in the oxidation or reduction reactions.
- Energy conversion is electrical into chemical.
- The strongest reductant will be oxidised at the (+) anode and the strongest oxidant will be reduced at the (-) cathode. Only when these have expired will the next strongest species, according to the electrochemical series react. Note that in concentrated solutions a less stronger oxidant or reductant may react. For example, when concentrated NaCl solution (brine) is electrolysed it is the Cl⁻ ions that react at the anode rather than the H₂O, however, when dilute solutions of NaCl are used it is, the more stronger reductant, H₂O that reacts at the anode.
- An electrochemical series is required to predict reactions in an electrolytic cell.

$\text{Au}^+(\text{aq}) + \text{e}^- \rightleftharpoons \text{Au}(\text{s})$	+1.68
$\text{Cl}_2(\text{g}) + 2\text{e}^- \rightleftharpoons 2\text{Cl}^-(\text{aq})$	+1.36
$\text{O}_2(\text{g}) + 4\text{H}^+(\text{aq}) + 4\text{e}^- \rightleftharpoons 2\text{H}_2\text{O}(\text{l})$	+1.23
$\text{Br}_2(\text{l}) + 2\text{e}^- \rightleftharpoons 2\text{Br}^-(\text{aq})$	+1.09
$\text{Ag}^+(\text{aq}) + \text{e}^- \rightleftharpoons \text{Ag}(\text{s})$	+0.80
$\text{Fe}^{3+}(\text{aq}) + \text{e}^- \rightleftharpoons \text{Fe}^{2+}(\text{aq})$	+0.77
$\text{O}_2(\text{g}) + 2\text{H}^+(\text{aq}) + 2\text{e}^- \rightleftharpoons \text{H}_2\text{O}_2(\text{aq})$	+0.68
$\text{I}_2(\text{s}) + 2\text{e}^- \rightleftharpoons 2\text{I}^-(\text{aq})$	+0.54
$\text{O}_2(\text{g}) + 2\text{H}_2\text{O}(\text{l}) + 4\text{e}^- \rightleftharpoons 4\text{OH}^-(\text{aq})$	+0.40
$\text{Cu}^{2+}(\text{aq}) + 2\text{e}^- \rightleftharpoons \text{Cu}(\text{s})$	+0.34
$\text{Sn}^{4+}(\text{aq}) + 2\text{e}^- \rightleftharpoons \text{Sn}^{2+}(\text{aq})$	+0.15
$\text{S}(\text{s}) + 2\text{H}^+(\text{aq}) + 2\text{e}^- \rightleftharpoons \text{H}_2\text{S}(\text{g})$	+0.14
$2\text{H}^+(\text{aq}) + 2\text{e}^- \rightleftharpoons \text{H}_2(\text{g})$	0.00
$2\text{H}_2\text{O}(\text{l}) + 2\text{e}^- \rightleftharpoons \text{H}_2(\text{g}) + 2\text{OH}^-(\text{aq})$	-0.83
$\text{Mn}^{2+}(\text{aq}) + 2\text{e}^- \rightleftharpoons \text{Mn}(\text{s})$	-1.18
$\text{Al}^{3+}(\text{aq}) + 3\text{e}^- \rightleftharpoons \text{Al}(\text{s})$	-1.66
$\text{Mg}^{2+}(\text{aq}) + 2\text{e}^- \rightleftharpoons \text{Mg}(\text{s})$	-2.37
$\text{Na}^+(\text{aq}) + \text{e}^- \rightleftharpoons \text{Na}(\text{s})$	-2.71

[Click](#) for more on predicting products of electrolysis.

Example 1

A dilute sodium chloride solution undergoes electrolysis using inert electrodes as shown below.

- What is the possible reaction that occurs at the anode?

Since at the anode oxidation takes place we should look for the strongest reductant present.

List all the reductants that are present in the solution.
We have two, H₂O and Cl⁻ ions.
Pick the strongest. In this case it is H₂O
 $2\text{H}_2\text{O}(\text{l}) \Rightarrow \text{O}_2(\text{g}) + 4\text{H}^+(\text{aq}) + 4\text{e}^-$
- What is the possible reaction that occurs at the cathode?

Now list all the oxidants present in the solution
We have H₂O and Na⁺ ions.
Pick the strongest. In this case it is H₂O.
 $2\text{e}^- + 2\text{H}_2\text{O}(\text{l}) \Rightarrow \text{H}_2(\text{g}) + 2\text{OH}^-(\text{aq})$

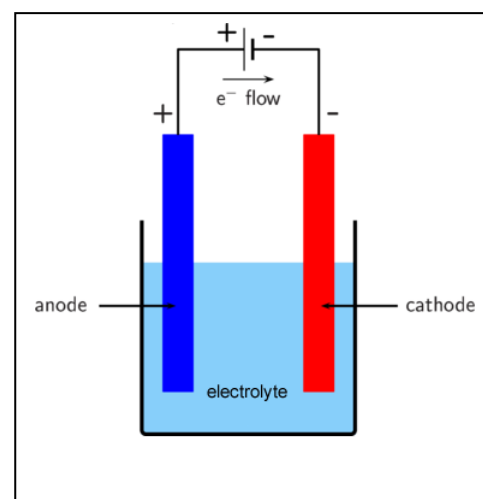

Example 2

Lithium metal is produced by the electrolysis of molten lithium chloride, LiCl.

- i. What are the products at the cathode and the anode?

At the cathode reduction takes place

List all the oxidants present

Li⁺ only hence

Li⁺(l) + e⁻ => Li(l)

Lithium metal and the cathode

At the anode oxidation takes place

List all the reductants present

Cl⁻ only hence

2Cl⁻(l) => Cl₂(g) + 2e⁻

Cl gas at the anode

- ii. Why is a solution of lithium chloride not used?

H₂O is a stronger oxidant than Li⁺ and a stronger reductant than Cl⁻, hence it would react to form an explosive mixture of oxygen and hydrogen gases.

Cl ₂ (g) + 2e ⁻ ⇌ 2Cl ⁻ (aq)	+1.36
O ₂ (g) + 4H ⁺ (aq) + 4e ⁻ ⇌ 2H ₂ O(l)	+1.23
Br ₂ (l) + 2e ⁻ ⇌ 2Br ⁻ (aq)	+1.09
Ag ⁺ (aq) + e ⁻ ⇌ Ag(s)	+0.80
Fe ³⁺ (aq) + e ⁻ ⇌ Fe ²⁺ (aq)	+0.77
O ₂ (g) + 2H ⁺ (aq) + 2e ⁻ ⇌ H ₂ O ₂ (aq)	+0.68
I ₂ (s) + 2e ⁻ ⇌ 2I ⁻ (aq)	+0.54
O ₂ (g) + 2H ₂ O(l) + 4e ⁻ ⇌ 4OH ⁻ (aq)	+0.40
Cu ²⁺ (aq) + 2e ⁻ ⇌ Cu(s)	+0.34
Sn ⁴⁺ (aq) + 2e ⁻ ⇌ Sn ²⁺ (aq)	+0.15
S(s) + 2H ⁺ (aq) + 2e ⁻ ⇌ H ₂ S(g)	+0.14
2H ⁺ (aq) + 2e ⁻ ⇌ H ₂ (g)	0.00
2H ₂ O(l) + 2e ⁻ ⇌ H ₂ (g) + 2OH ⁻ (aq)	-0.83
Mn ²⁺ (aq) + 2e ⁻ ⇌ Mn(s)	-1.18
Al ³⁺ (aq) + 3e ⁻ ⇌ Al(s)	-1.66
Mg ²⁺ (aq) + 2e ⁻ ⇌ Mg(s)	-2.37
Na ⁺ (aq) + e ⁻ ⇌ Na(s)	-2.71
Ca ²⁺ (aq) + 2e ⁻ ⇌ Ca(s)	-2.87
K ⁺ (aq) + e ⁻ ⇌ K(s)	-2.93
Li ⁺ (aq) + e ⁻ ⇌ Li(s)	-3.04

Example 3

An electrolytic cell known as the Downs Cell, pictured on the right, operates at high currents with molten NaCl.

- i. Write the equation for the reaction that occurs at the cathode.

Reduction occurs at the cathode and hence the strongest oxidant will react.

Na⁺(l) + e⁻ => Na(l)

- ii. Identify substance "A". *Na(l)*

- iii. Write the equation for the reaction that occurs at the anode. *Oxidation occurs at the anode and hence the strongest reductant will react 2Cl⁻(l) => Cl₂(g) + 2e⁻*

- iv. Identify substance "B". *Cl₂(g)*

- v. Consider the electrolytic cell on the right, it has aqueous NaCl as the electrolyte.

a) Label the anode and the cathode

Electrode "A" is the anode and electrode "B" is the cathode.

b) Give the balanced ionic equations for the reactions that occur at each electrode.

Electrode "A" – oxidation takes place hence the strongest reductant present (Cl⁻) will react. 2Cl⁻(aq) => Cl₂(g) + 2e⁻

Electrode "B"- reduction takes place and hence the strongest oxidant present (H₂O) will react. 2H₂O(l) + 2e⁻ => H₂(g) + 2OH⁻(aq)

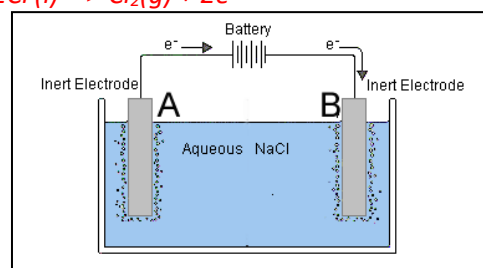
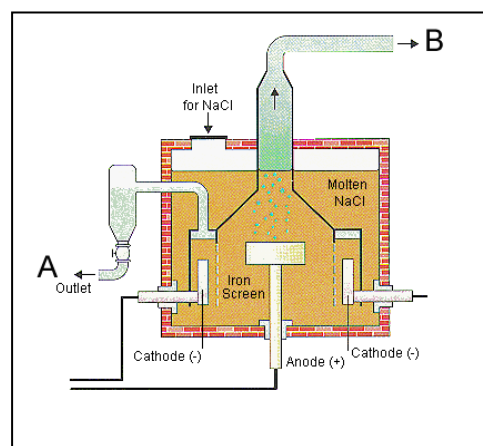

1) Electrolysis of water takes place with the apparatus shown on the right.

i. To what terminal of an external power source will the anode be connected to?

The positive terminal. The external power source can be thought of as an electron pump using energy to pump electrons out of the anode(+) where oxidation takes place and pump them into the cathode (-) where reduction takes place.

ii. Write the balanced ionic equations for the reactions taking place at electrodes "A" and "B".

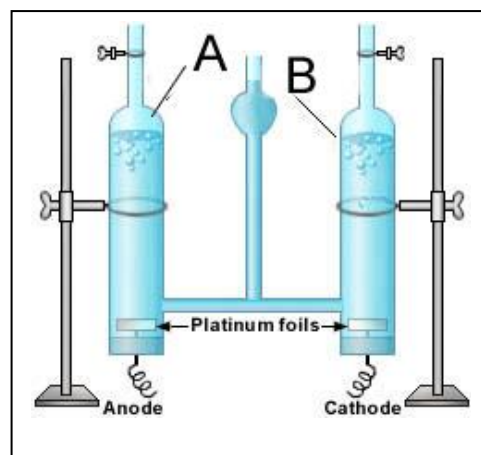

Since water is the only substance present we do not have to identify all the possible oxidants and reductants present.

H₂O will react at the anode and the cathode as it is both an oxidant and a reductant.

At the anode (A) $2\text{H}_2\text{O}(l) \Rightarrow \text{O}_2(g) + 4\text{H}^+(aq) + 4e^-$

At the cathode (B) $2\text{H}_2\text{O}(l) + 2e^- \Rightarrow \text{H}_2(g) + 2\text{OH}^-(aq)$

iii. Mg(NO₃)₂ powder is added to the water. Explain, using the table below, how the products formed at each electrode change?

Since we now have Mg²⁺ and NO₃⁻ ions present we must first look at finding the strongest oxidant that will react at the cathode and the strongest reductant that will react at the anode. Looking the table on the right we see that the strongest oxidant present is still H₂O and the strongest reductant is also H₂O.

At the cathode the following reaction takes place

$2\text{H}_2\text{O}(l) + 2e^- \rightarrow \text{H}_2(g) + 2\text{OH}^-(aq)$

at the anode the reaction is as shown below.

$2\text{H}_2\text{O}(l) \rightarrow 4\text{H}^+(aq) + \text{O}_2(g) + 4e^-$

iv. Write the balanced equation to the overall reaction occurring in the electrolytic cell in iii. above.

$2\text{H}_2\text{O}(l) \Rightarrow 2\text{H}_2(g) + \text{O}_2(aq)$

$\text{Cl}_2(g) + 2e^- \rightleftharpoons 2\text{Cl}^-(aq)$	+1.36
$\text{O}_2(g) + 4\text{H}^+(aq) + 4e^- \rightleftharpoons 2\text{H}_2\text{O}(l)$	+1.23
$\text{Br}_2(l) + 2e^- \rightleftharpoons 2\text{Br}^-(aq)$	+1.09
$\text{Ag}^+(aq) + e^- \rightleftharpoons \text{Ag}(s)$	+0.80
$\text{Fe}^{3+}(aq) + e^- \rightleftharpoons \text{Fe}^{2+}(aq)$	+0.77
$\text{O}_2(g) + 2\text{H}^+(aq) + 2e^- \rightleftharpoons \text{H}_2\text{O}_2(aq)$	+0.68
$\text{I}_2(s) + 2e^- \rightleftharpoons 2\text{I}^-(aq)$	+0.54
$\text{O}_2(g) + 2\text{H}_2\text{O}(l) + 4e^- \rightleftharpoons 4\text{OH}^-(aq)$	+0.40
$\text{Cu}^{2+}(aq) + 2e^- \rightleftharpoons \text{Cu}(s)$	+0.34
$\text{Sn}^{4+}(aq) + 2e^- \rightleftharpoons \text{Sn}^{2+}(aq)$	+0.15
$\text{S}(s) + 2\text{H}^+(aq) + 2e^- \rightleftharpoons \text{H}_2\text{S}(g)$	+0.14
$2\text{H}^+(aq) + 2e^- \rightleftharpoons \text{H}_2(g)$	0.00
$2\text{H}_2\text{O}(l) + 2e^- \rightleftharpoons \text{H}_2(g) + 2\text{OH}^-(aq)$	-0.83
$\text{Mn}^{2+}(aq) + 2e^- \rightleftharpoons \text{Mn}(s)$	-1.18
$\text{Al}^{3+}(aq) + 3e^- \rightleftharpoons \text{Al}(s)$	-1.66
$\text{Mg}^{2+}(aq) + 2e^- \rightleftharpoons \text{Mg}(s)$	-2.37
$\text{Na}^+(aq) + e^- \rightleftharpoons \text{Na}(s)$	-2.71
$\text{Ca}^{2+}(aq) + 2e^- \rightleftharpoons \text{Ca}(s)$	-2.87
$\text{K}^+(aq) + e^- \rightleftharpoons \text{K}(s)$	-2.93
$\text{Li}^+(aq) + e^- \rightleftharpoons \text{Li}(s)$	-3.04

- 2) Magnesium is one of the most abundant elements on Earth. It is used extensively in the production of magnesium-aluminium alloys. It is produced by the electrolysis of molten magnesium chloride. A schematic diagram of the electrolytic cell is shown below.

The design of this cell takes into account the following properties of both magnesium metal and magnesium chloride:

- Molten magnesium reacts vigorously with oxygen.
- At the temperature of molten magnesium chloride, magnesium is a liquid.
- Molten magnesium has a lower density than molten magnesium chloride and forms a separate layer on the surface.

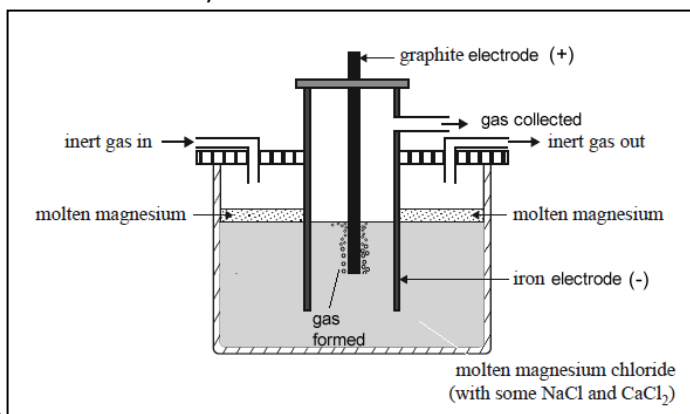

- a) Label the following electrodes as the anode or cathode

iron **Cathode** _____
 graphite **Anode** _____

- b) Explain why an inert gas is used?

To prevent Mg(l) coming into contact with oxygen in the air.

- c) Write a balanced half-equation for the reaction occurring at the

i. anode **$2Cl(l) \Rightarrow Cl_2(g) + 2e$**

ii. Cathode **$Mg^{2+}(l) + 2e \Rightarrow Mg(l)$**

- d) The melting point of a compound can often be lowered by the addition of small amounts of other compounds. In an industrial process, this will save energy. In this cell, NaCl and CaCl₂ are used to lower the melting point of MgCl₂, however, FeCl₂ cannot be used. Explain why NaCl and CaCl₂ can be used but FeCl₂ cannot.

According to the electrochemical series Na⁺ and Ca²⁺ are weaker oxidants than Mg²⁺, hence, will not react to form Na(l) and Ca(l).

If FeCl₂ was used, Fe²⁺ is a stronger oxidant than Mg²⁺ and hence will form Fe(l) instead of Mg(l).

- e) What difference would it make to the half-cell reactions if the graphite was replaced with iron? Write the half-equation for any different half-cell reaction. Justify your answer.

$Sn^{2+}(aq) + 2e^- \rightleftharpoons Sn(s)$	-0.14
$Ni^{2+}(aq) + 2e^- \rightleftharpoons Ni(s)$	-0.25
$Co^{2+}(aq) + 2e^- \rightleftharpoons Co(s)$	-0.28
$Cd^{2+}(aq) + 2e^- \rightleftharpoons Cd(s)$	-0.40
$Fe^{2+}(aq) + 2e^- \rightleftharpoons Fe(s)$	-0.44
$Zn^{2+}(aq) + 2e^- \rightleftharpoons Zn(s)$	-0.76
$2H_2O(l) + 2e^- \rightleftharpoons H_2(g) + 2OH^-(aq)$	-0.83
$Mn^{2+}(aq) + 2e^- \rightleftharpoons Mn(s)$	-1.18
$Al^{3+}(aq) + 3e^- \rightleftharpoons Al(s)$	-1.66
$Mg^{2+}(aq) + 2e^- \rightleftharpoons Mg(s)$	-2.37
$Na^+(aq) + e^- \rightleftharpoons Na(s)$	-2.71
$Ca^{2+}(aq) + 2e^- \rightleftharpoons Ca(s)$	-2.87

Since the graphite is the anode and the site of oxidation the strongest reductant will react. Fe(s) is a stronger reductant than Cl⁻. The anode will be consumed according to the equation $Fe(s) \Rightarrow Fe^{2+}(l) + 2e$

The consequence of having Fe²⁺ ions in the electrolyte would also change the reaction happening at the cathode. As Fe²⁺ ions migrate to the cathode the following reaction will take place $Fe^{2+}(l) + 2e \Rightarrow Fe(s)$ because Fe²⁺ is a stronger oxidant than Mg²⁺.

3) A mineral ore contains a mixture of compounds of lead and calcium, in approximately equal proportions. A chemist extracts the metal ions by roasting the ore in air and treating the product with acid. The solution that contains the $\text{Pb}^{2+}(\text{aq})$ and $\text{Ca}^{2+}(\text{aq})$ is then placed in an electrolytic cell as shown in the diagram below.

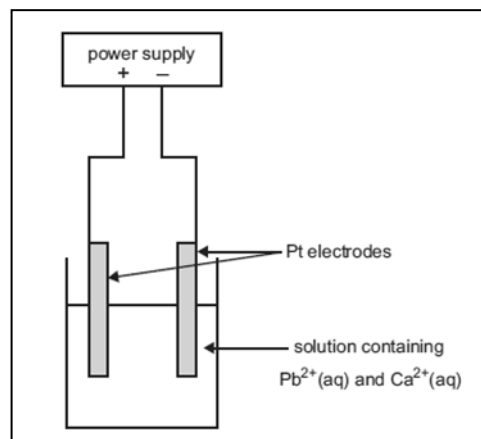

a) When the current begins to flow in the cell, write equations for the half reaction that is likely to occur at the

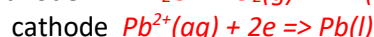

b) After some time has elapsed, a new half reaction occurs at one of the electrodes. Assume diffusion of ions in the electrolyte takes some time

Write the equation for this half reaction.

After some time has elapsed the H^+ produced at the anode will react at the cathode according to the equation below.

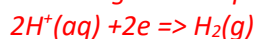

It could also be that the Pb^{2+} ions as they get used up will be replaced at the cathode by the next strongest oxidant present (H_2O) as the reaction below will occur.

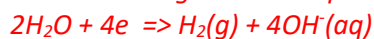

c) If the chemist had used copper electrodes instead of platinum electrodes, how would this have affected the half reactions the moment the power was switched on? Indicate the new reactions and the electrodes each one takes place at.

Copper is oxidised as it is the strongest reductant present at the anode (positive electrode) $\text{Cu}(\text{s}) \Rightarrow \text{Cu}^{2+}(\text{aq}) + 2\text{e}^-$. The reaction at the cathode remains the same.